

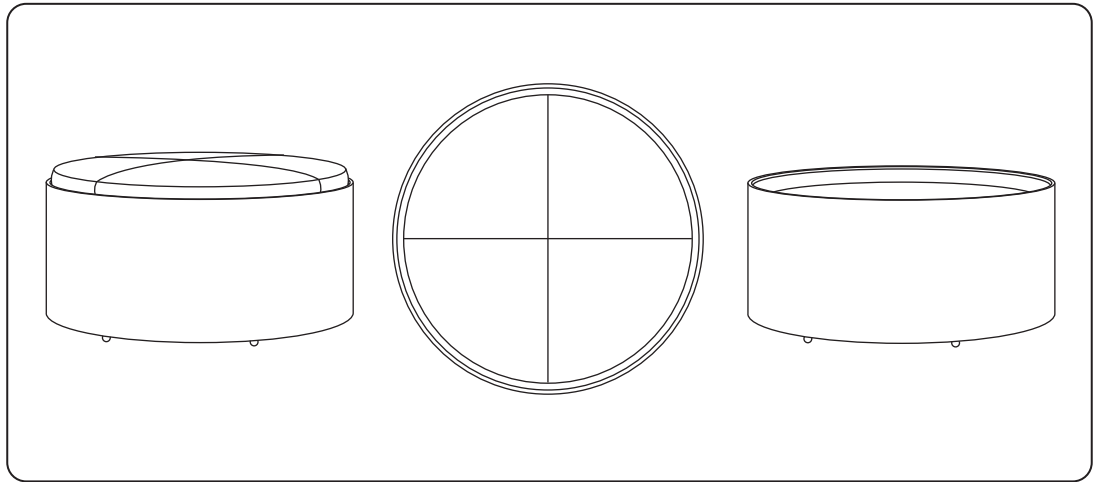

# Stoll 90

by Jordi & Borja Veciana



## TECHNICAL SPECIFICATIONS

Dimensions - cm/inch	Ø 90/35,4 - H. 40(42)/15,7(16,5)
Packaging - cm/inch	L. 94/37 - D. 94/37 - H. 45/17,7
Weight - kg/lbs	39,7/87,3
#cartons	1
Volume - m <sup>3</sup>	0,40

### Color

- Walnut stained  
ST90WWN
- Swamp Oak  
ST90WOK

### Option

- Cushion black leather  
CUST90BK
- Cushion orange leather  
CUST90OR
- Cushion dark brown leather  
CUST90DB
- Cushion camel leather  
CUST90CA
- Cushion customer own leather  
CUST90CL